

## Sampling Oriented Specimens

The remanent magnetization and magnetic anisotropy are measured in the specimen coordinate system. However, in the geological and geophysical interpretation, they should be presented either in the geographical coordinate system or in another special coordinate system (e.g. system of the structural cross, palaeogeographical system). This is possible only if the specimen is taken in an oriented way so that the data measured in the specimen coordinate system can be mathematically transformed into another system.

In the measurement by the LAM series astatic magnetometers, JR series spinner magnetometers, and KLY series Kappabridges, the specimen coordinate system used is represented by right hand Cartesian coordinate system defined as shown in Fig. 1. The  $x_1$  axis is the direction of the main fiducial mark drawn on the specimen (simple arrow on the cube, simple arrow on the frontal face of the cylinder).

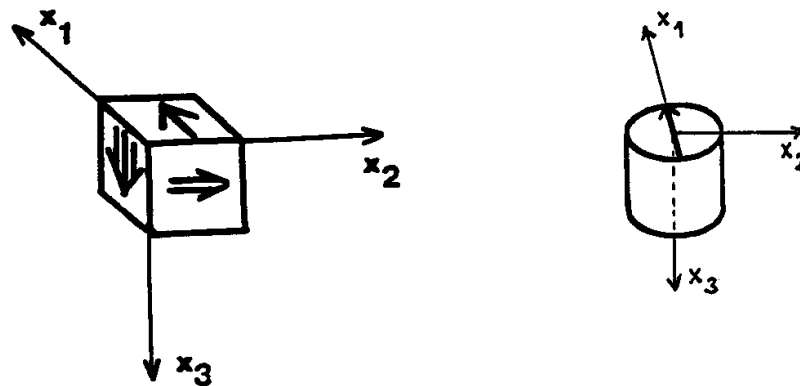

Fig. 1 Definition of the specimen coordinate system

The transformation of a vector or a second rank tensor from the specimen coordinate system (with axes  $x_1, x_2, x_3$ ) to the geographic system (with axes  $y_1, y_2, y_3$ ) is described by the following matrix equations (Nye 1957; Jelínek 1977)

$$\mathbf{R} = \mathbf{T} \mathbf{r}, \quad \mathbf{K} = \mathbf{T} \mathbf{k} \mathbf{T}', \quad (1)$$

where  $\mathbf{r}$  and  $\mathbf{R}$  in the vector in the specimen system and geographic system respectively,  $\mathbf{k}$  and  $\mathbf{K}$  is the second rank tensor in the specimen system and geographic system respectively, and  $\mathbf{T}$  is the transformation matrix ( $\mathbf{T}'$  is the transpose of  $\mathbf{T}$ ). The transformation matrix consists of the cosines of the angles between the individual axes (Fig. 2) as follows

$$\mathbf{T} = \begin{vmatrix} \cos(y_1, x_1) & \cos(y_1, x_2) & \cos(y_1, x_3) \\ \cos(y_2, x_1) & \cos(y_2, x_2) & \cos(y_2, x_3) \\ \cos(y_3, x_1) & \cos(y_3, x_2) & \cos(y_3, x_3) \end{vmatrix} \quad (2)$$

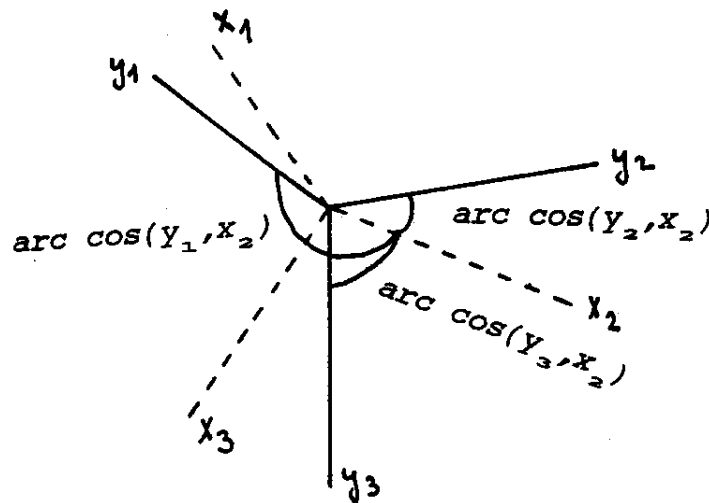

Fig. 2 Scheme of coordinate transformation from specimen to geographic system

The oriented sampling is made almost exclusively using the geological compass which, unfortunately, cannot measure any of the above angles. This compass measures only the angles in the horizontal plane (with respect to the magnetic north; they are called azimuths) and the angles in the vertical plane (with respect to the horizontal line; they are called dips or plunges). The technique of the oriented sampling must be chosen in such a way that the cosines of the eq.(2) can be constructed from the measured azimuths and dips/plunges.

There are two common techniques of the oriented sampling of block specimens (see Figs. 3 to 6). The first one is as follows: (1) a horizontal line with an arrow parallel to the strike direction is drawn on the sampled rock face (Fig. 3), (2) strike of the arrowed line is measured (clockwise from zero (magnetic north) to  $360^\circ$ ), (3) dip of the plane on which the arrowed line is drawn is measured (from zero (horizontal) to  $90^\circ$  (vertical) or even  $180^\circ$ ), (4) cube specimen or cylindrical specimen is cut or drilled in such a way that the  $x_1$  axis is parallel to the strike line,  $x_2$  axis is parallel to the dip line and  $x_3$  is directed towards to rock (Fig. 5). If the strike is denoted as  $\varphi$  and the dip as  $\psi$ , the transformation matrix of eqn.(2) can be written

$$\mathbf{T} = \begin{vmatrix} \cos(\varphi) & -\sin(\varphi) \cos(\psi) & \sin(\varphi) \sin(\psi) \\ \sin(\varphi) & \cos(\varphi) \cos(\psi) & -\cos(\varphi) \sin(\psi) \\ 0 & \sin(\psi) & \cos(\psi) \end{vmatrix} \quad (3)$$

Then, it is easy to transform vectors or second rank tensors from the specimen system to the geographic system using eqn. (1).

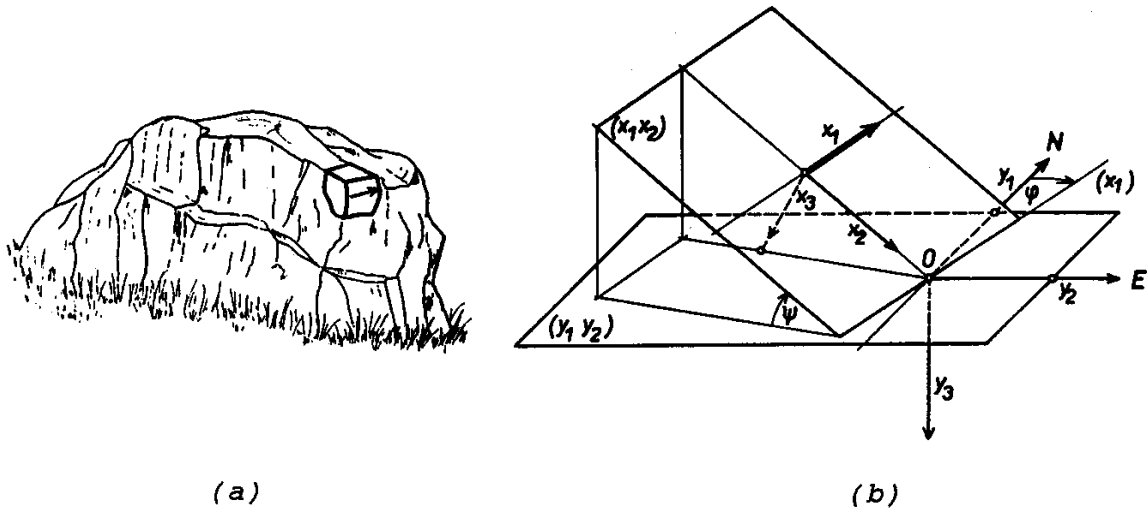

Fig. 3 The first way of oriented sampling block specimens

The second one is as follows: (1) dip line with an arrow oriented downwards is drawn on the sampled rock face (Fig. 4), (2) azimuth of the arrowed line is measured (clockwise from zero (magnetic north) to  $360^\circ$ ), (3) dip of the plane on which the arrowed line is drawn is measured from zero (horizontal) to  $90^\circ$  (vertical) or even  $180^\circ$ , (4) cube specimen or cylindrical specimen is cut or drilled in such a way that the  $x_1$  axis is parallel to the dip line and  $x_3$  is directed towards to rock (Fig. 5). If the azimuth of the dip line is denoted as  $\varphi$  and the dip as  $\psi$ , the transformation matrix in the eqn.(2) can be written

$$\mathbf{T} = \begin{vmatrix} \cos(\varphi) \cos(\psi) & -\sin(\varphi) & -\cos(\varphi) \sin(\psi) \\ \sin(\varphi) \cos(\psi) & \cos(\varphi) & -\sin(\varphi) \sin(\psi) \\ \sin(\psi) & 0 & \cos(\psi) \end{vmatrix} \quad (4)$$

In addition, there are another sampling techniques. For example, if cores are drilled directly in the field using portable drilling machine, the fiducial mark is usually oriented upwards, but the azimuth of the dip line is measured.

In our earlier programs for the on line measurement of remanence and/or magnetic anisotropy, the transformation matrix must have been constructed for each our customer specially in order to respect his/her special way of oriented sampling. As this was very ineffective, we have developed another technique which works with a general transformation matrix and the user describes his/her particular way of oriented sampling by means of the so called orientation parameters. Inputting these parameters into our programs, the convenient transformation matrix is specified automatically. These parameters are four,  $P_1$  to  $P_4$ , and defined as shown in Fig. 8.

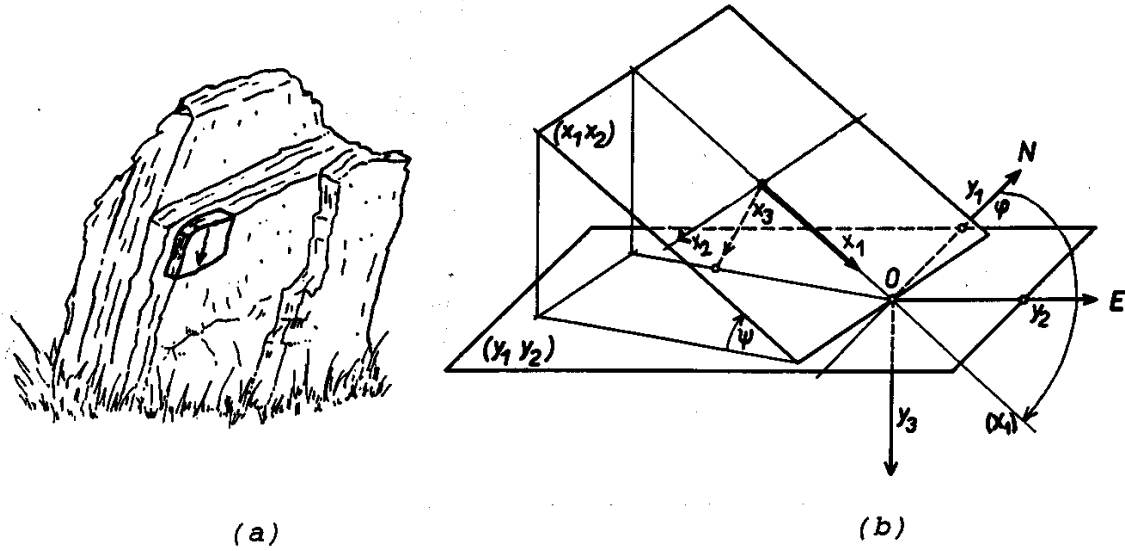

Fig. 4 The second way of oriented sampling block specimens

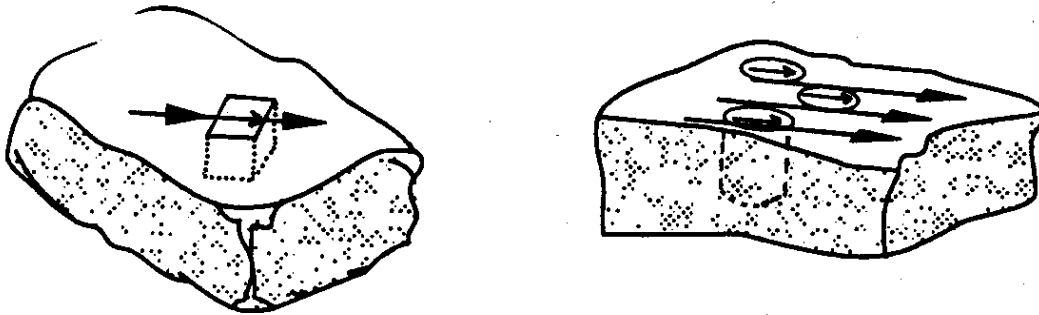

Fig. 5 Cutting/drilling the cube/cylinder from block specimen

The components of the general transformation matrix are as follows

$$T(1,1) = \cos(\varphi') \cos(\psi') \cos(\zeta) - \sin(\varphi') \sin(\zeta)$$

$$T(2,1) = \sin(\varphi') \cos(\psi') \cos(\zeta) + \cos(\varphi') \sin(\zeta)$$

$$T(3,1) = \sin(\psi') \cos(\zeta)$$

$$T(1,2) = -\cos(\varphi') \cos(\psi') \sin(\zeta) - \sin(\varphi') \cos(\zeta)$$

$$T(2,2) = -\sin(\varphi') \cos(\psi') \sin(\zeta) + \cos(\varphi') \cos(\zeta)$$

$$T(3,2) = -\sin(\psi') \sin(\zeta)$$

$$T(1,3) = -\cos(\varphi') \sin(\psi')$$

$$T(2,3) = -\sin(\varphi') \sin(\psi')$$

$$T(3,3) = \cos(\psi')$$

where

$$\varphi'' = \varphi + (P_1 - P_3) * 30$$

$$\varphi' = \varphi'' - (P_1 - 6) * 30$$

$$\text{if } P_2 = 0 \text{ then } \psi' = \psi$$

$$\text{if } P_2 = 90 \text{ then } \psi' = 90 - \psi$$

$$\zeta = (P_1 - 6) * 30.$$

In the use of AMS in structural geology it is useful to know the relationship of the directions of principal susceptibilities to mesoscopic fabric elements, such as bedding, cleavage, schistosity and various lineations, and/or with respect to the coordinate systems defined by these fabric elements. In palaeomagnetism it is necessary to know the orientation of the remanence after tectonic correction. For this reason, the orientations of these fabric elements are measured in the field. Foliations are measured in principle in two ways: (1) azimuth of the dip (1 to 360 degrees) and dip (1 to 90 degrees) ( $P_4$  parameter is 0) (Fig. 6a), (2) strike (1 to 360 degrees) and dip (1 to 90 degrees) ( $P_4$  parameter is 90) (Fig. 6c).

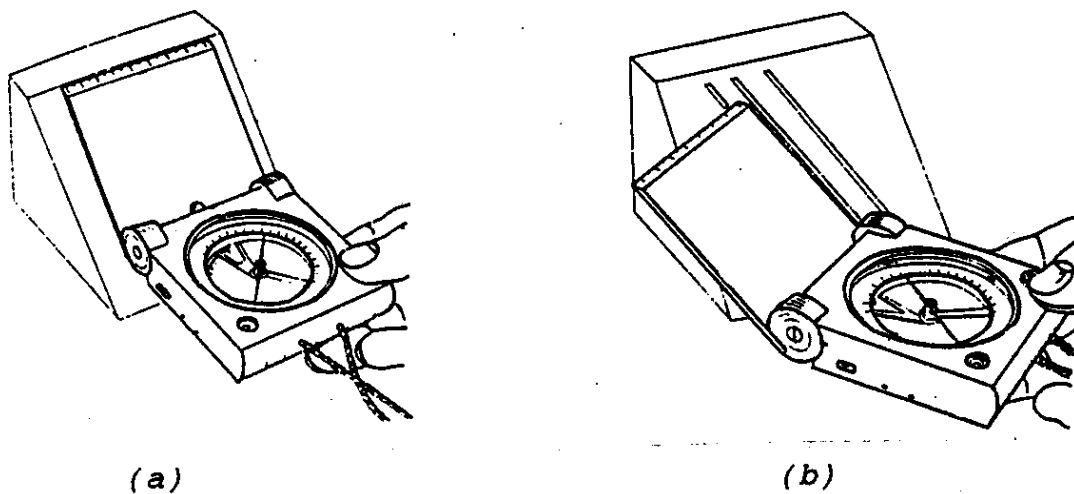
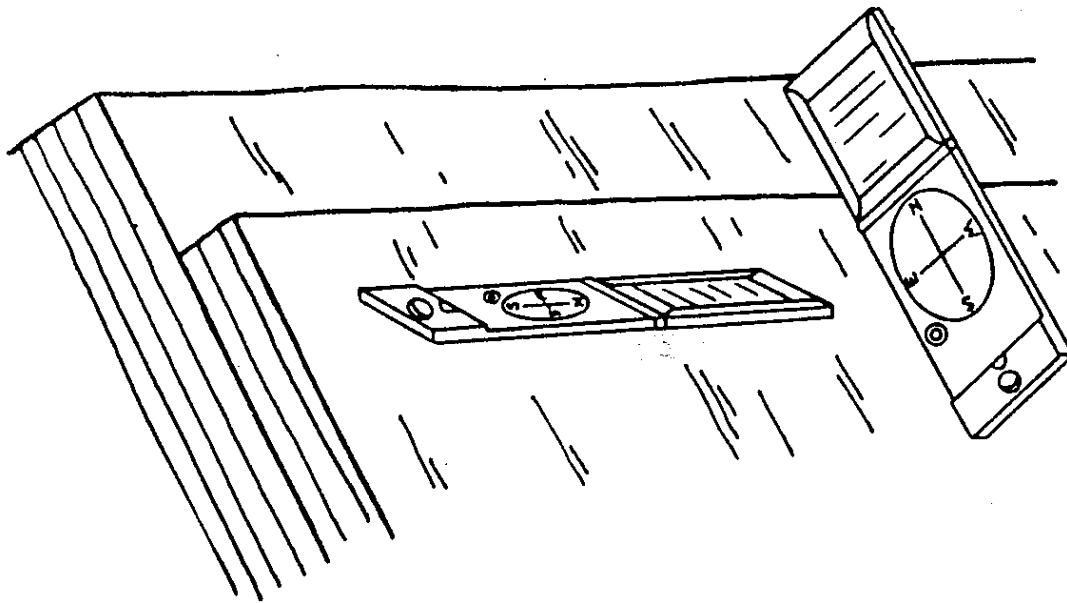

Fig. 6 Measurements of the orientations of mesoscopic foliation (a) and lineation (b) using geological compass. Azimuth of dip and dip ( $P_4 = 0$ ) of a foliation are measured and trend and plunge of a lineation.

The usefulness of the use of the general transformation matrix concept can be very well illustrated on the example of the oriented sampling made through in situ drilling of oriented specimens using portable drilling machine and the COT-1 orienting fixture which fits the Freiberg type geological compass. This sampling is made as follows:

(1) A cylinder is drilled using a portable drilling machine into the depth of 6 cm in minimum, but it should not be removed from the outcrop before its orientation is measured. The diameter of the drilled cylinder must not exceed 2.54 cm and the cylinder should not be curved.



*Fig. 6c Measurement of the orientation of a mesoscopic foliation using geological compass; strike and dip are measured ( $P_4 = 90$ ).*

(2) The geological compass is fixed on the orienting fixture in such a way that the letter S on the compass scale is oriented towards the slit for marking the drilled cylindrical specimens on the cylindrical part of the fixture.

(3) Loosen the screw fixing the dip level and insert the orienting fixture on the drilled cylindrical specimen and rotate both the whole fixture about the cylinder axis and the dip level about the horizontal axis until the water level on the compass indicates horizontal orientation of the compass scale. Tight up the dip screw.

(4) Using soft copper wire or thin water proof pen, make a line on the cylinder side following the slit on the cylindrical part of the fixture.

(5) Measure the azimuth (it must be read at the north side of the magnetic needle in the interval between  $0^\circ$  and  $360^\circ$ ).

(6) Measure the plunge of the cylinder axis on the scale fixed on the fixture. The downward drilled cylinders have plunges ranging from  $0^\circ$  to  $90^\circ$  (printed in black on the fixture COT-1), while the upward drilled cylinders have plunges from  $91^\circ$  to  $180^\circ$  (printed in red on the fixture scale).

(7) Remove the drilled cylinder from the rock outcrop using screw driver and hammer.

(8) Draw arrows to orientation line in such a way that the arrows are oriented towards the rock (Fig. 7).

(9) Cut the cylinder for the height of 21 to 22 mm and draw the fiducial mark on the frontal part of the cylinder following Fig. 7.

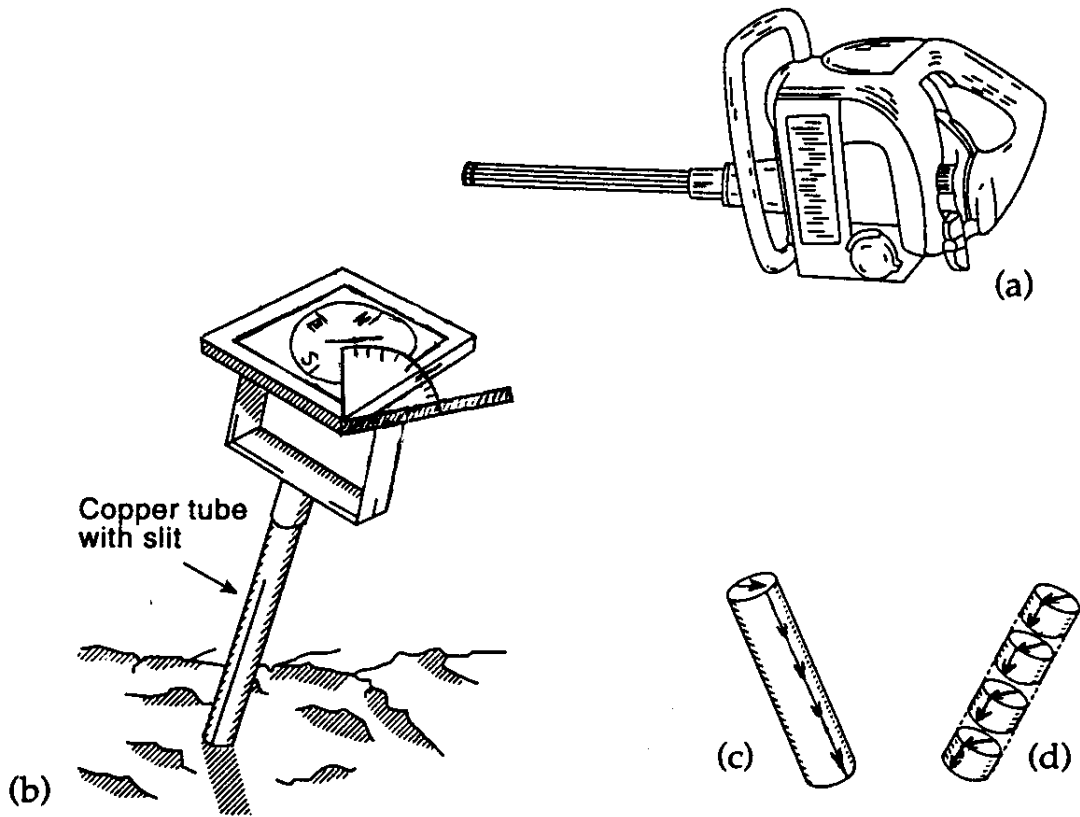
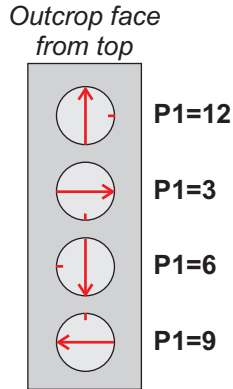
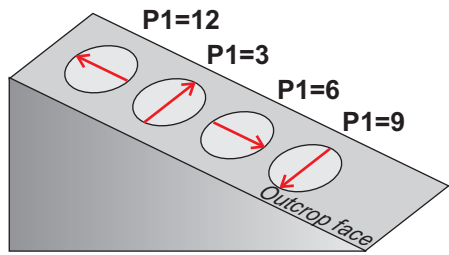

Fig. 7 Drilling oriented cores in the field using portable drilling machine. (a) portable drilling machine, (b) orienting the drilled core, (c) cylinder marking, (d) cylinder slicing into standard-size specimens.

It should be emphasized that the above way of sampling differs very much from that used in sampling block specimens. The fiducial mark drawn on the drilled cylinder is oriented upwards, while the measured azimuth is that of the downward oriented side of the fiducial mark. For this reason, different orientation parameters are used for the information how the fiducial mark is drawn and for the information how the azimuth is measured. The  $P_1$  parameter is 12 (see Fig. 8), while the  $P_3$  parameter is 6. The  $P_2$  parameter is 90, because the plunge of the cylinder axis is measured.

# ORIENTATION PARAMETERS

## Parameter P1



P1 is a clock value orientation of the **Arrow** drawn on the specimen frontal plane.

The **Arrow** represents the x-axis of the *Specimen coordinate system* (right-handed) and may be drawn Upslope (P1=12), to the Right (P1=3), Downslope (P1=6), or to the Left (P1=9).

Note that the **Azimuth** of the **Arrow** may, or may not, be measured (see Parameter P3).

## Parameter P2

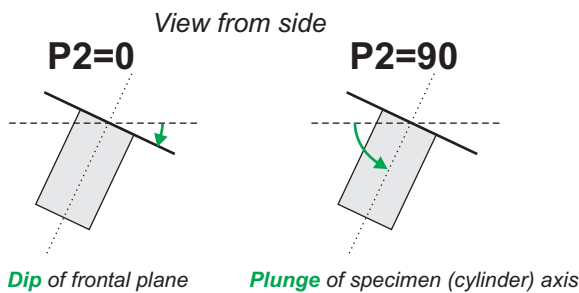

P2 indicates whether the **Dip** of the specimen frontal plane or the **Plunge** of the specimen (cylinder) axis is measured.

P2 may attain two values:  
**P2=0** indicates that the **Dip** of the specimen frontal plane is measured.  
**P2=90** indicates that the **Plunge** of the specimen (cylinder) axis is measured.

## Parameter P3

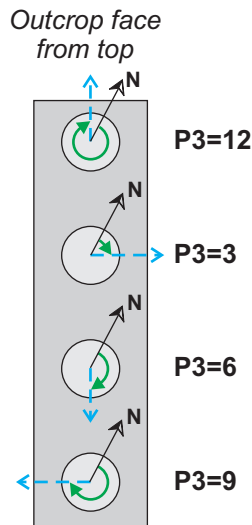
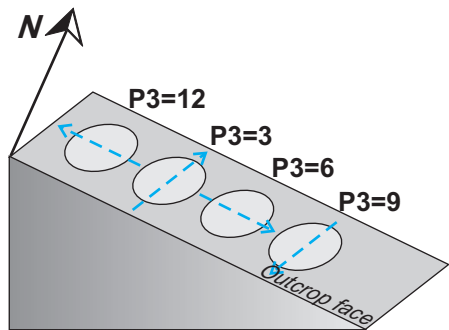

P3 is a clock value of the **Direction** which is measured using the geological compass and expressed as **Azimuth** of the specimen.

Note that the measured **Direction** may, or may not, coincide with the **Arrow** (see Parameter P1).

## Parameter P4

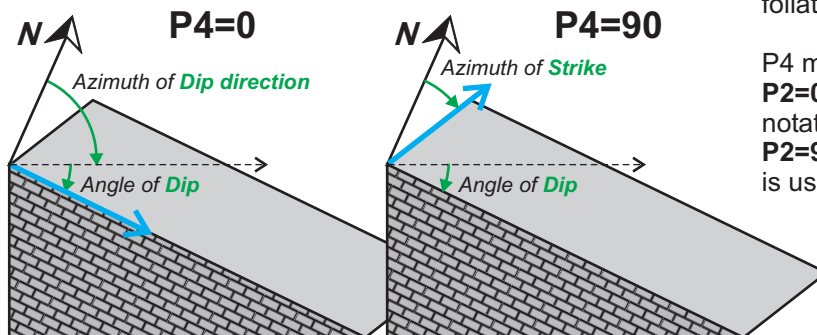

P4 refers to the measurement of mesoscopic foliations adjacent to the specimen.

P4 may attain two values:  
**P2=0** indicates that the **Dip direction / Dip** notation is used.  
**P2=90** - indicates that the **Strike / Dip** notation is used (Strike is right oriented).

## Legend

**Red**    **Marking drawn on specimen**  
**Green**    **Measured angles**  
**Blue**    **Measured direction (not drawn)**